



# DRIVING THE FUTURE OF LOGISTICS

**Multimodal transport with Serbia. The Backbone of Rail  
Logistics in South-Eastern Europe**

Innovations, Efficiency, and  
Sustainability in Motion.

IBS Congress 16./17.04.2026 Zagreb



**Steel Express Logistics** is a logistics company headquartered in Belgrade, Serbia. Our main scope of business is the organization of railway transport. We have been present at the Serbian market since December 2020. Our staff are professionals with proven track record of fulfilling demands of the modern market and providing complete logistics service with a key focus on railway transport.

- **Our success is rooted in the strong bonds we build and maintain with our clients.**
- **We are focused on providing logistics solutions with visible results**

- Our experience gained in optimizing logistics services, as well as a large number of clients throughout the region, both at the domestic and at the international market, affirms our company as a leader in this industry.**
- 





# HISTORY OF SEL



Established as a privately owned company in 2020 with main focus on:



**Intermodal transport**

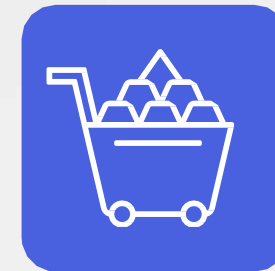

**Raw materials**



**Liquids**



**Finished steel products**



**Grains**



# CONVENTIONAL RAIL TRANSPORT



In cooperation with railway operators in the region and countries of Central and Southern Europe, we provide a complete service for the organization of conventional rail transport



# INTERMODAL SERVICES



Through the organization of intermodal transport, we connect the terminals of Southeast, Central, and Southern Europe, as well as countries in the region



In cooperation with the ports on the Adriatic Sea, we have provided a connection with the European logistics network, and in this way, we complete the entire logistics solution for the client.





# MARITIME & ROAD TRANSPORTATION

In addition to our specialization in rail transport, Steel Express Logistics offers comprehensive sea and road transport solutions, providing clients with borderless logistics support.

- Sea transport ( FCL/LCL) from all key global ports – import and export.
- Reliable network of partners worldwide.  
Road transport support for deliveries to/from ports or terminals.
- Possibility of combined (multimodal) transport – connecting sea, rail, and road.
- Full-service organization from pick up to final delivery of goods-



**Clean Mobility  
and Operations**



**Eco-Conscious  
Supply Chains**





# INTERMODAL RAIL ROUTES AND TRANSIT TIME

- DPT Pancevo – Ljubljana: 48 h
- DPT Pancevo – Munich: 96 h
- DPT Pancevo – Ludwigshafen: 120 h
- DPT Pancevo – Köln: 120 h
- DPT Pancevo – Duisburg: 120 h
- DPT Pancevo – Rotterdam: 120 h

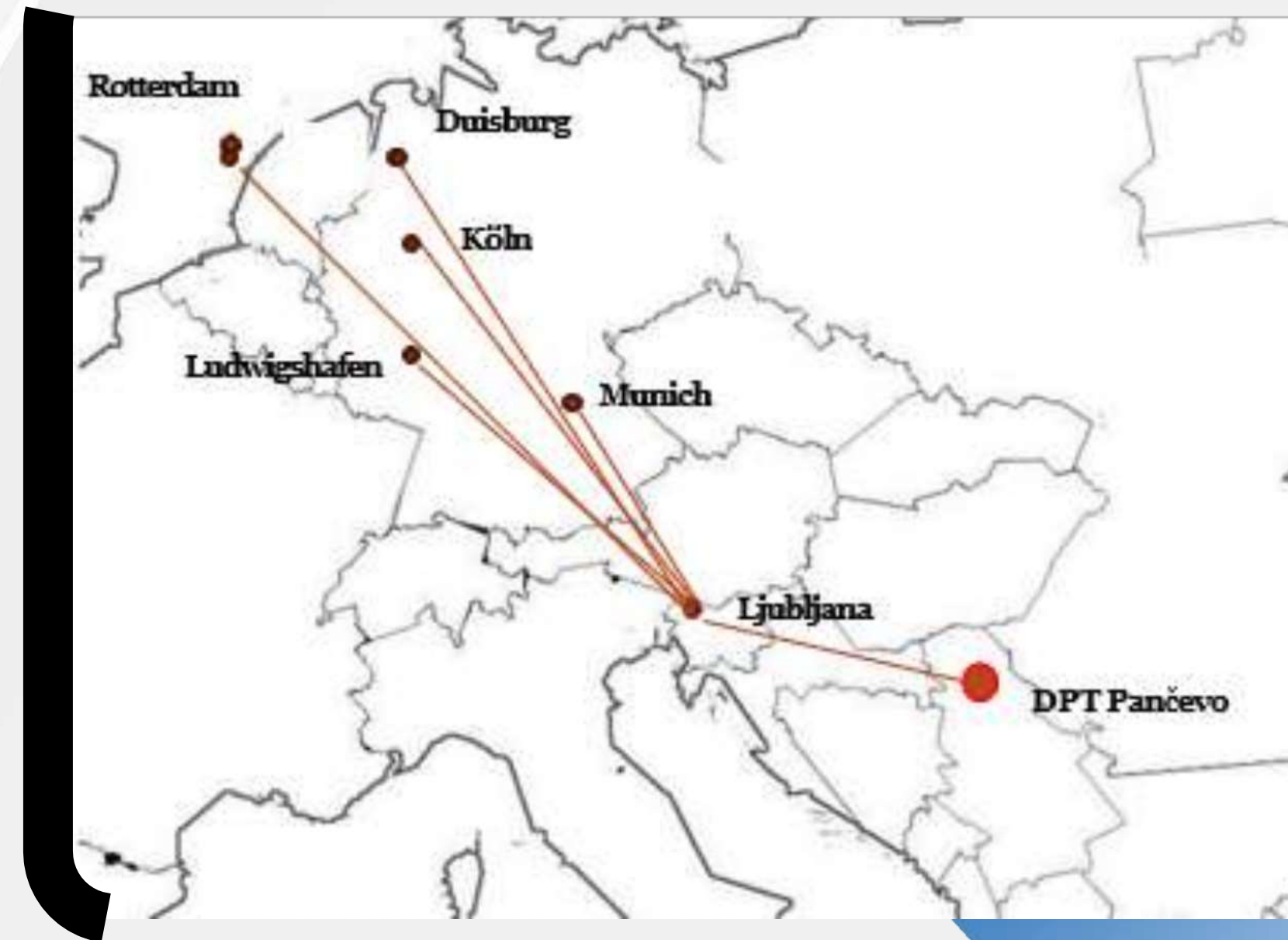



# INTERMODAL RAIL ROUTES AND TRANSIT TIME



DPT Pančevo – Interporto Padova: 48 h





# INTERMODAL RAIL ROUTES AND TRANSIT TIME

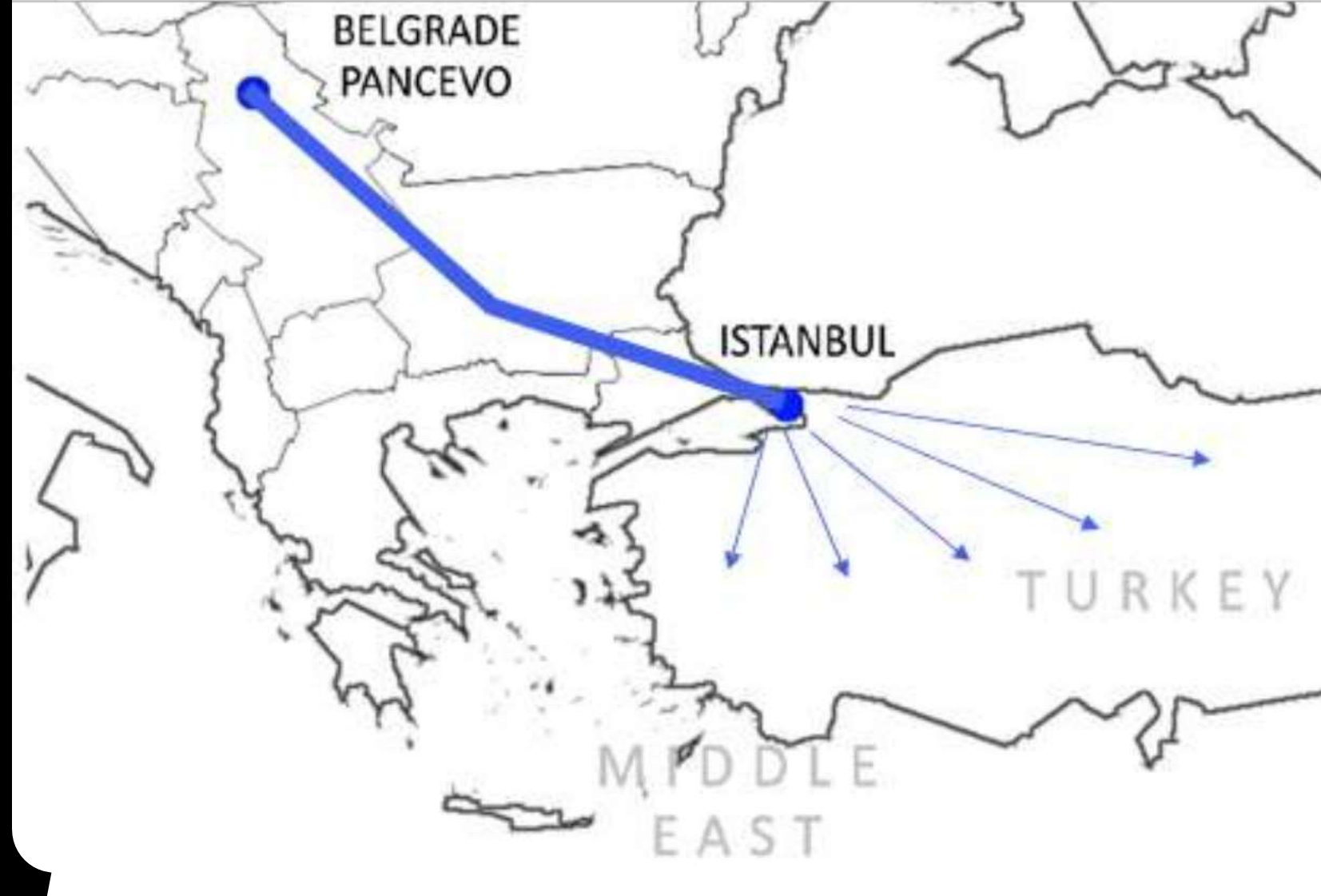

- Three intermodal trade lanes, which are crucial as connections for the Serbian market with Europe
- Weekly service between DPT and Halkali/Terkerdag
- Direct connection of Serbia with Turkey and the Middle East





# WAGONS

Thanks to our own fleet of various series and types of wagons SEL is able to meet all customers' needs, ensuring reliable and high-quality services together with the highest safety standards in transport.

We possess tank and intermodal wagons, and our long-term plan is to continuously extend our fleet.



# INTERMODAL WAGONS

Two-axel flat wagon with low hinged side walls and stanchions.

- The wagon is designed for the transportation of containers, light bulk items, products of the metallurgy, machinery, and building industries, timber and lumber, road vehicles, and farm machines.

Length over buffers: 13.860 mm

Wagon empty weight: 14.000-15.000 kg

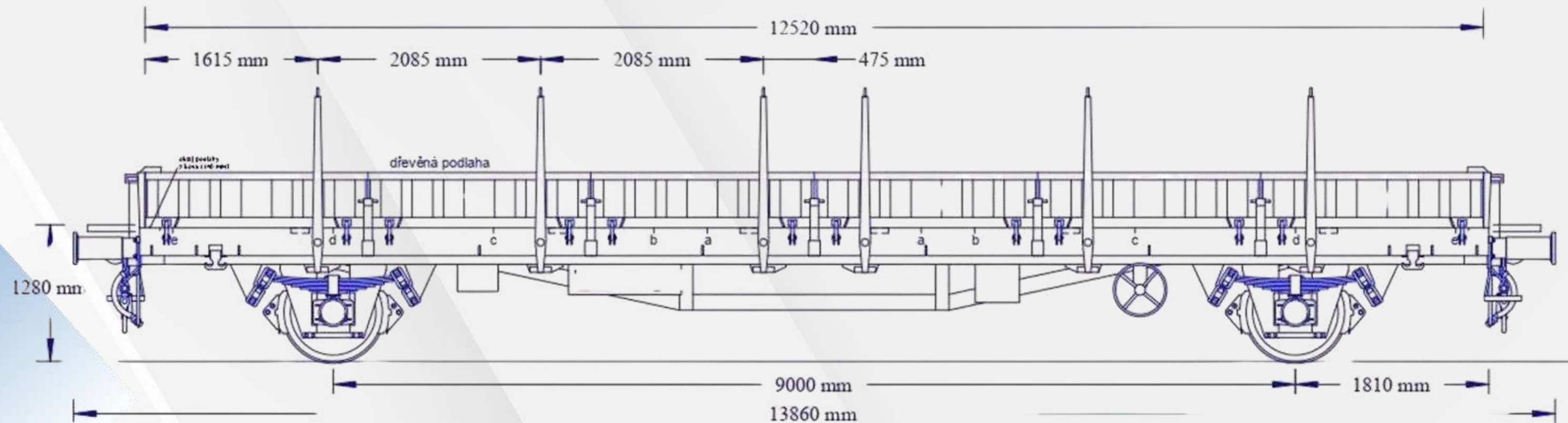



# INTERMODAL WAGONS

**Four-axle wagon for intermodal transportation.**

The wagon is designed for the transportation of large containers (size 20ft,30ft,40ft,45ft) and swap bodies with a uniform or mixed arrangement of the load along the entire length of the wagon.

Length over buffers: 19.640 mm

Wagon empty weight: 18.800-20.000kg



# INTERMODAL WAGONS

## Six-axle articulated wagon for intermodal transportation (80ft)

- The wagon is designed for the transportation of containers (20ft,30ft,40ft)
- Length over buffers:26.700 mm
- Wagon empty weight:27.600-29.200 kg

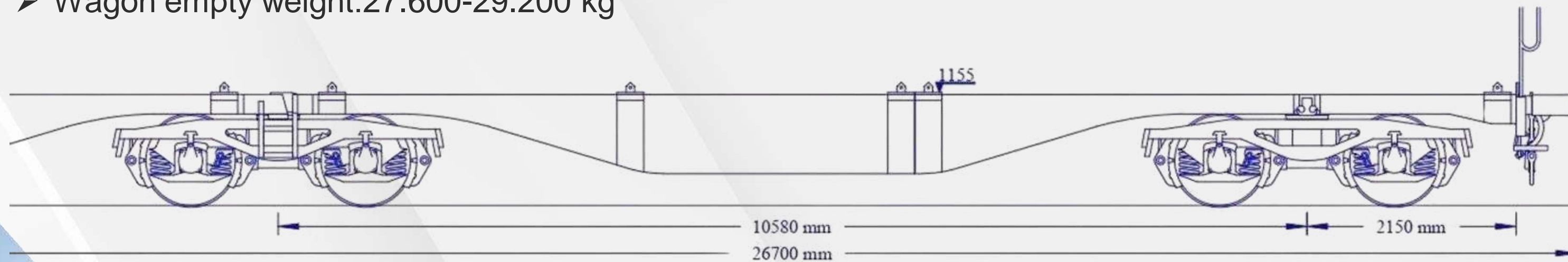

# INTERMODAL WAGONS

## Six-axle articulated wagon for intermodal transportation (90ft)

- The wagon is designed for the transportation of containers (20ft,30ft,40ft,45ft) and swap bodies a uniform or mixed arrangement of the load along the entire length of the wagon.
- Length over buffers: 29.590 mm
- Wagon empty weight: 29.000-29.900 kg

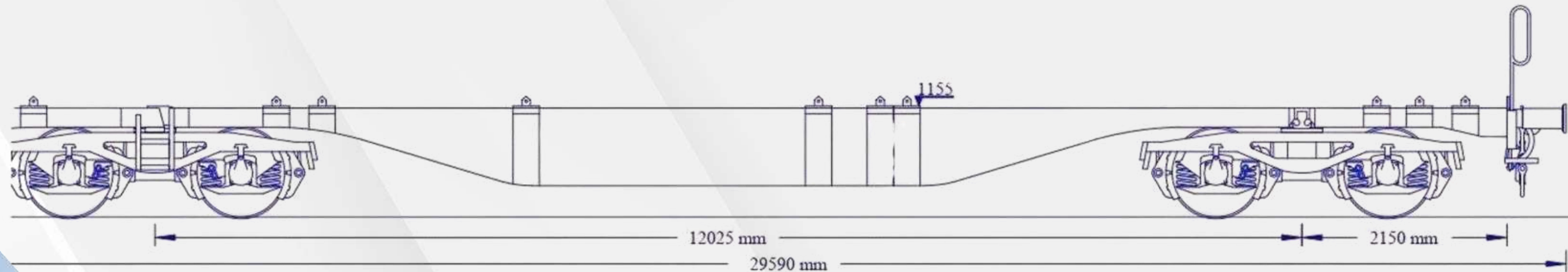

# GRAIN WAGONS



**Self-discharging covered hopper is suitable for transport of bulk loads - grain, corn, soya, etc., which need to be protected against weather conditions.**

- The loading opening is covered with a movable roof. Six bottom unloading openings are covered with sliding doors. This wagon is designed according to TSI, EN, and UIC for TEN RIV traffic operation. The wagon is loaded from the top after the roof is opened. The roof is manually operated from ground level from both sides of the wagon and platform. The wagon is unloaded through six unloading openings from the bottom. Sliding valves are manually operated from both wagon sides - each valve separately. Transported materials are unloaded between the rails.

Length over buffers: 14350 mm

Wagon empty weight: 27.600-29.200 kg

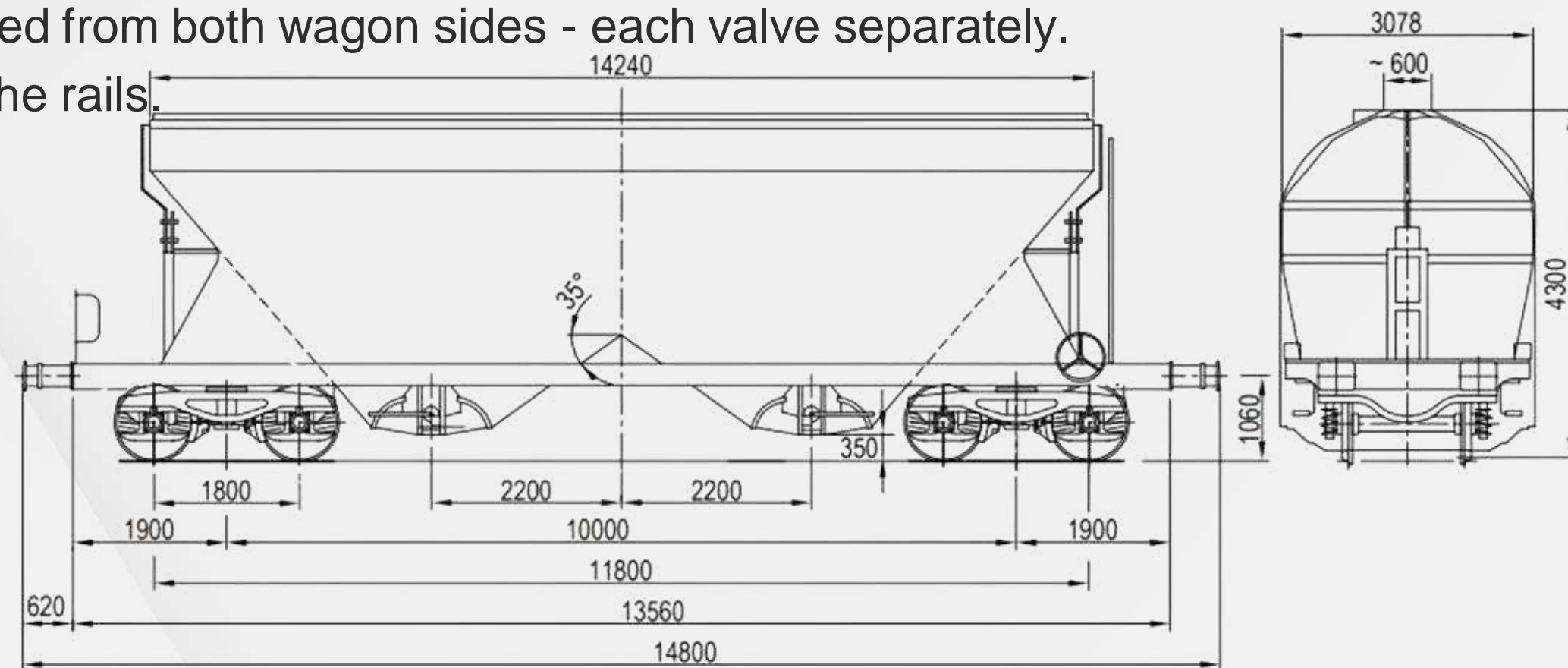

# TANK WAGONS



**Four-axle wagon with a loading capacity of more than 80 m<sup>3</sup>**

- The wagon is designed for the transportation of white petroleum products (gasoline, diesel...) and for black petroleum products (heavy fuel oil, heavy oils...)
- Length over buffers: 15.140 mm
- Wagon empty weight: 21.630 kg

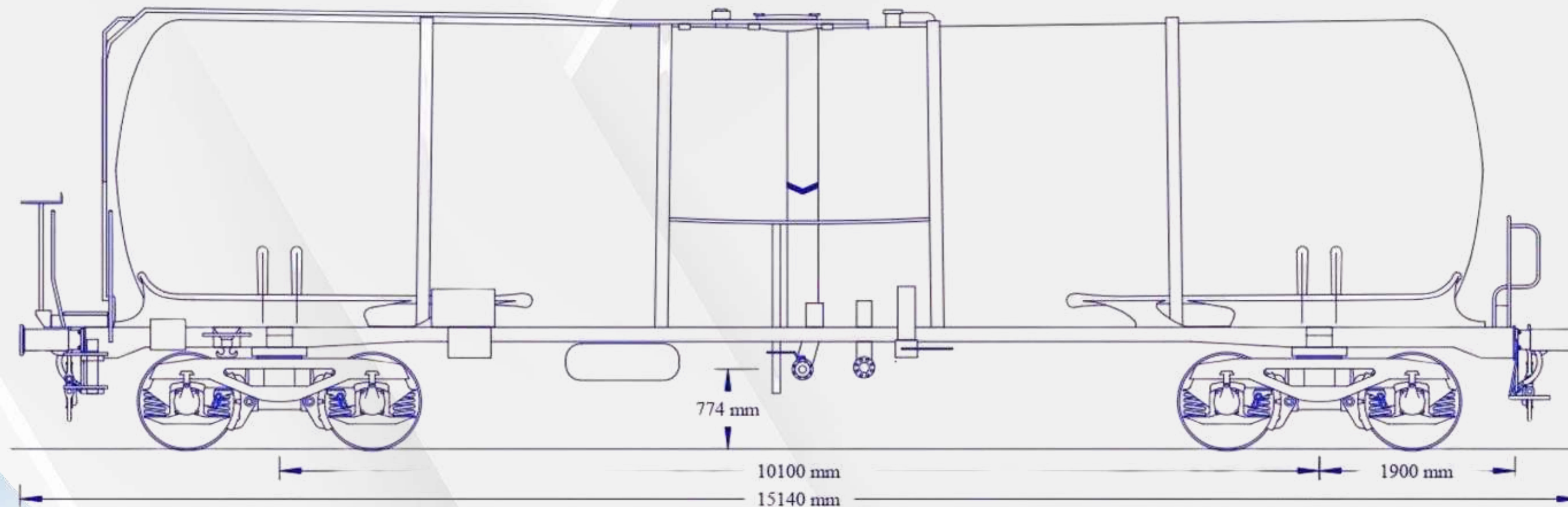

# STRATEGIC & DEVELOPMENT



## **Fleet Investment**

- Investment in wagon fleet
- Focus on intermodal wagons
- Expansion of container fleet

## **📦 Intermodal Solutions**

- Containers used in intermodal transport
- Terminal-to-terminal logistics solutions

## **💻 Digitalization**

- Operational software (active from Jan 2024)
- BI system for operational & financial reporting (July 2024)
- DMS for administration and finance



# OUR CLIENTS



# OUR PARTNERS

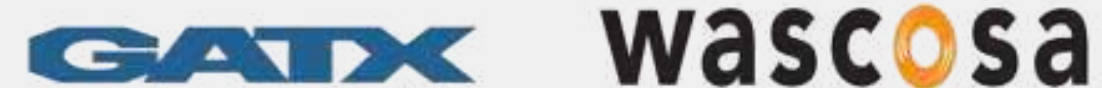



# THANK YOU FOR YOUR ATTENTION

Together, let's shape a smarter, faster,  
and greener future for logistics.



[office@selogistics.rs](mailto:office@selogistics.rs)

Web: [www.selogistics.rs](http://www.selogistics.rs)



**Nenad Nikolic**  
Sales Representative